

# IL311/IL211

## Highly Flexible Voltage Comparators

The ability to operate from a single power supply of 5.0V to 30V or  $\pm 15$  V split supplies, as commonly used with operational amplifiers, makes the LM211/LM311 a truly versatile comparator. Moreover, the inputs of the device can be isolated from system ground while the output can drive loads referenced either to ground, the Vcc or the VEE supply. This flexibility makes it possible to drive DTL, RTL, TTL, or MOS logic. The output can also switch voltages to 50 V at currents to 50mA. Thus the LM211/LM311 can be used to drive relays, lamps or solenoids.

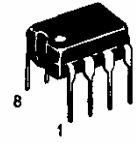

**N SUFFIX**  
PLASTIC PACKAGE  
CASE 626



**D SUFFIX**  
PLASTIC PACKAGE  
CASE 751  
(SO-8)

### PIN CONNECTIONS

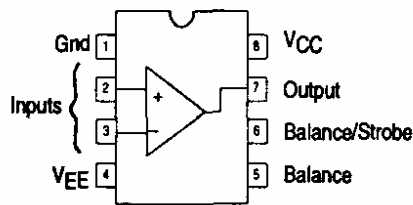

(Top View)

### ORDERING INFORMATION

Device	Operating Temperature Range	Package
LM211D	TA ss 25° to +85°C	SO-8
LM311 D LM311N	TA = 0° to +70-C	SO-8 Plastic DIP

### MAXIMUM RATINGS (TA = +25°C, unless otherwise noted.)

Rating	Symbol	LM211	LM311	Unitt
Total Supply Voltage	$V_{cc} +  V_{EE} $	36	36	Vdc
Output to Negative Supply Voltage	$V_Q - V_{EE}$	50	40	Vdc
Ground to Negative Supply Voltage	$V_{EE}$	30	30	Vdc
Input Differential Voltage	$V_{ID}$	$\pm 30$	$\pm 30$	Vdc
Input Voltage (Note 2)	$V_{in}$	$\pm 15$	$\pm 15$	Vdc
Voltage at Strobe Pin	-	$V_{cc}$ to $V_{cc}^{-5}$	$V_{cc}$ to $V_{cc}^{-5}$	Vdc
Power Dissipation and Thermal Characteristics Plastic DIP	$P_D$	625		mW
Derate Above TA = +25°C	$1/\theta_{JA}$	5.0		mW/°C
Operating Ambient Temperature Range	TA	-25 to +85	0 to +70	°C
Operating Junction Temperature	T <sub>J</sub> (max)	+150	+150	°C
Storage Temperature Range	T <sub>stg</sub>	-65 to +150	-65 to +150	°C

# IL311/IL211

## ELECTRICAL CHARACTERISTICS ( $V_{CC} = +15\text{ V}$ , $V_{EE} = -15\text{ V}$ , $T_A = 25^\circ\text{C}$ . unless otherwise noted [Note 1].)

Characteristic	Symbol	LM211			LM311			Unit
		Min	Typ	Max	Min	Typ	Max	
Input Offset Voltage (Note 3) $R_s \leq 50\text{ k}\Omega$ , $T_A = +25^\circ\text{C}$ $R_s \leq 50\text{ k}\Omega$ , $T_{low} \leq T_A \leq T_{high}^*$	$V_{io}$	-	0.7	3.0	-	2.0	7.5	mV
Input Offset Current (Note 3) $T_A = +25^\circ\text{C}$ $T_{low} \leq T_A \leq T_{high}^*$	$I_{io}$	-	1.7	10	-	1.7	50	$\mu\text{A}$
Input Bias Current $T_A = +25^\circ\text{C}$ $T_{low} \leq T_A \leq T_{high}^*$	$I_{IB}$	-	45	100	-	45	250	$\mu\text{A}$
Voltage Gain	$A_V$	40	200	-	40	200	-	V/mV
Response Time (Note 4)		-	200	-	-	200	-	ns
Saturation Voltage $V_{ID} \leq -5.0\text{ mV}$ , $I_o = 50\text{ mA}$ , $T_A = 25^\circ\text{C}$ $V_{ID} \leq -10\text{ mV}$ , $I_o = 50\text{ mA}$ , $T_A = 25^\circ\text{C}$ $V_{CC} \geq 4.5\text{ V}$ , $V_{EE} = 0$ , $T_{low} \leq T_A \leq T_{high}^*$ $V_{ID} \leq 6.0\text{ mV}$ , $I_{sink} \leq 8.0\text{ mA}$ $V_{ID} \leq 10\text{ mV}$ , $I_{sink} \leq 60\text{ mA}$	$V_{OL}$	-	0.75	1.5	-	-	-	V
Strobe "On" Current (Note 5)	$I_s$	-	3.0	-	-	3.0	-	mA
Output Leakage Current $V_{ID} \geq 5.0\text{ mV}$ , $V_o = 35\text{ V}$ , $T_A = 25^\circ\text{C}$ , $I_{strobe} = 3.0\text{ mA}$ $V_{ID} \geq 10\text{ mV}$ , $V_o = 35\text{ V}$ , $T_A = 25^\circ\text{C}$ , $I_{strobe} = 3.0\text{ mA}$ $V_{ID} \geq 5.0\text{ mV}$ , $V_o = 35\text{ V}$ , $T_{low} \leq T_A \leq T_{high}^*$		-	0.2	10	-	-	-	$\mu\text{A}$
		-	-	-	-	0.2	50	nA
		-	0.1	0.5	-	-	-	$\mu\text{A}$
Input Voltage Range ( $T_{low} \leq T_A \leq T_{high}^*$ )	$V_{ICR}$	-14.5	-14.7 to 13.8	+13.0	-14.5	-14.7 to 13.8	+13.0	V
Positive Supply Current	$I_{CC}$	-	+2.4	+6.0	-	+2.4	+7.5	mA
Negative Supply Current	$I_{EE}$	-	-1.3	-5.0	-	-1.3	-5.0	mA

**NOTES:** 1. Offset voltage, offset current and bias current specifications apply for a supply voltage range from a single 5.0 V supply up to  $\pm 15\text{ V}$  supplies.

2. This rating applies for  $\pm 15\text{ V}$  supplies. The positive input voltage limit is 30 V above the negative supply. The negative input voltage limit is equal to the negative supply voltage or 30 V below the positive supply, whichever is less.

3. The offset voltages and offset currents given are the maximum values required to drive the output within a voltage of either supply with a 1.0 mA load. Thus, these parameters define an error band and take into account the "worst case" effects of voltage gain and input impedance-

4. The response time specified is for a 100 mV input step with 5-0 mV overdrive.

5. Do not short the strobe pin to ground; it should be current driven at 3.0 mA to 5.0 mA.

Figure 1. Circuit Schematic

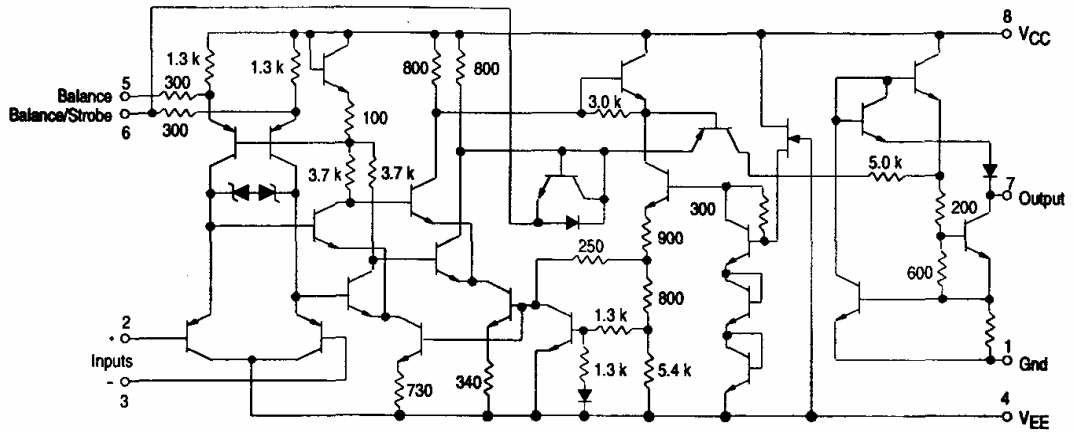

Figure 2. Input Bias Current versus Temperature

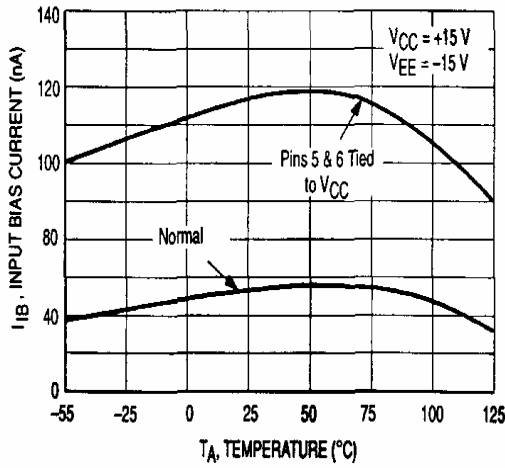

Figure 3. Input Offset Current versus Temperature

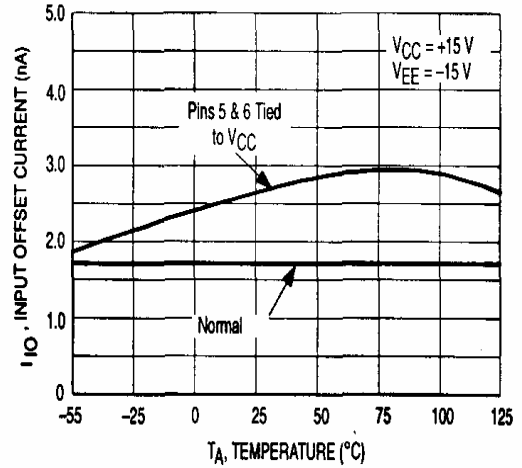

Figure 4. Input Bias Current versus Differential Input Voltage

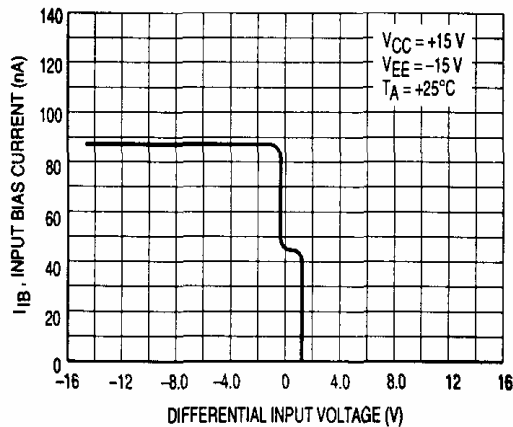
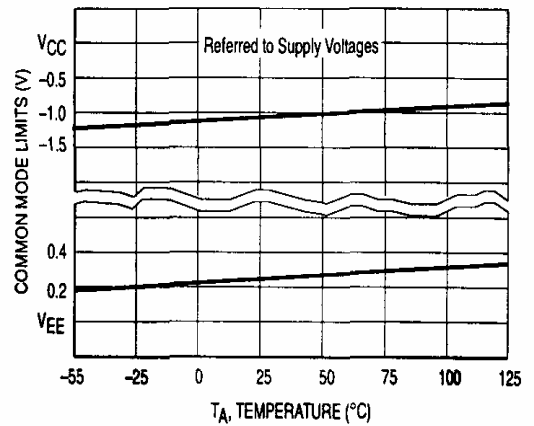
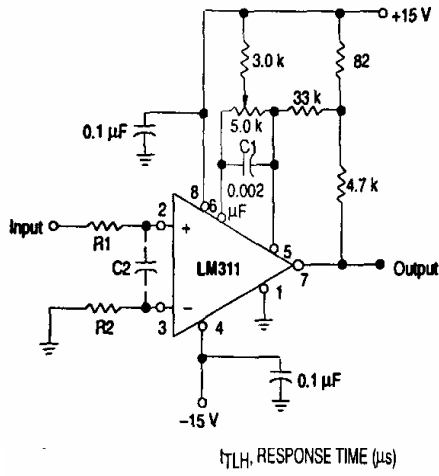

Figure 5. Common Mode Limits versus Temperature



## APPLICATIONS INFORMATION

**Figure 15. Improved Method of Adding Hysteresis Without Applying Positive Feedback to the Inputs**



**Figure 16. Conventional Technique for Adding Hysteresis**

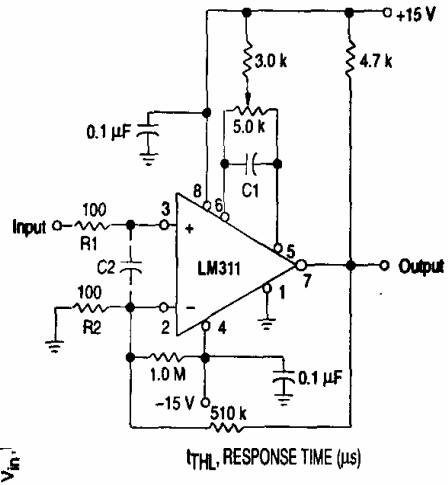

**Figure 8. Response Time for Various Input Overdrives**

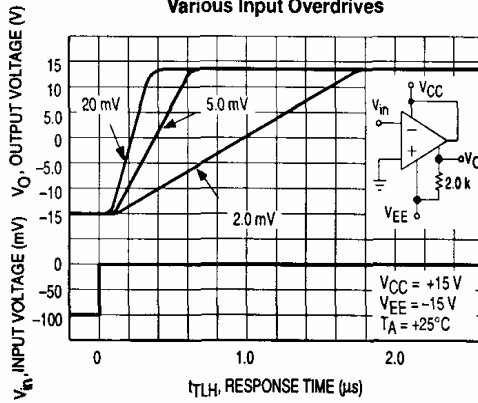

**Figure 9. Response Time for Various Input Overdrives**

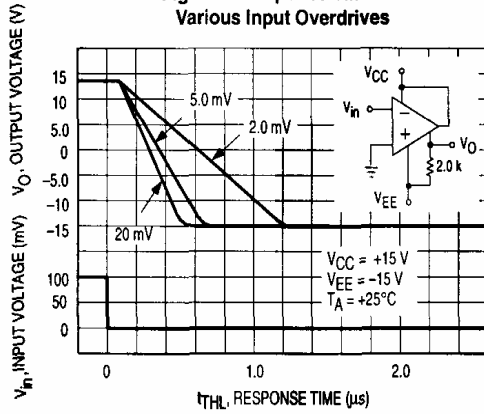

**Figure 10. Output Short Circuit Current Characteristics and Power Dissipation**

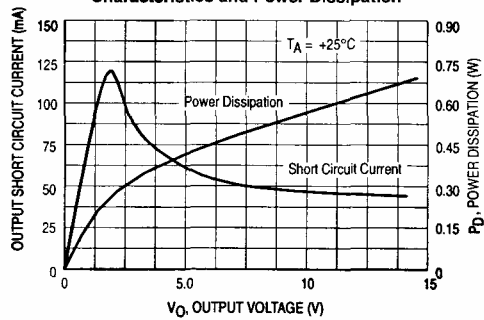

**Figure 11. Output Saturation Voltage versus Output Current**

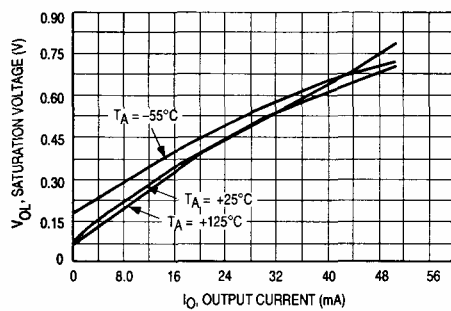

**Figure 12. Output Leakage Current versus Temperature**

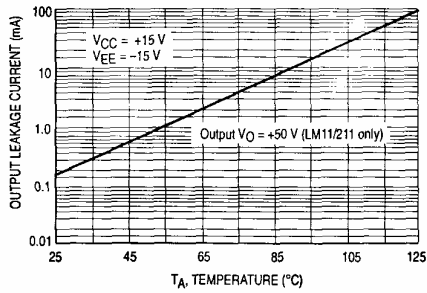

**Figure 13. Power Supply Current versus Supply Voltage**

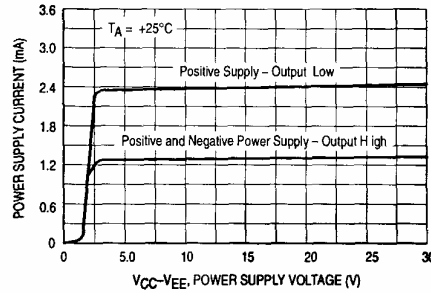

**Figure 14. Power Supply Current versus Temperature**

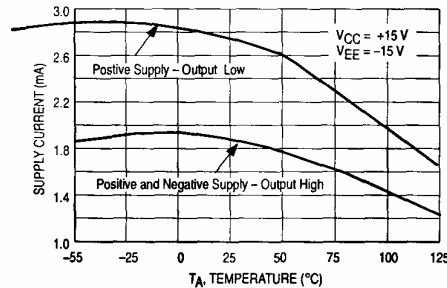

## TECHNIQUES FOR AVOIDING OSCILLATIONS IN COMPARATOR APPLICATIONS

When a high speed comparator such as the LM211 is used with high speed input signals and low source impedances, the output response will normally be fast and stable, providing the power supplies have been bypassed (with 0.1  $\mu\text{F}$  disc capacitors), and that the output signal is routed well away from the inputs (Pins 2 and 3) and also away from Pins 5 and 6.

However, when the input signal is a voltage ramp or a slow sine wave, or if the signal source impedance is high (1.0 k $\Omega$  to 100 k $\Omega$ ), the comparator may burst into oscillation near the crossing-point. This is due to the high gain and wide bandwidth of comparators like the LM211 series. To avoid oscillation or instability in such a usage, several precautions are recommended, as shown in Figure 15.

The trim pins (Pins 5 and 6) act as unwanted auxiliary inputs. If these pins are not connected to a trim-pot, they should be shorted together. If they are connected to a trim-pot, a 0.01  $\mu\text{F}$  capacitor (C1) between Pins 5 and 6 will minimize the susceptibility to AC coupling. A smaller capacitor is used if Pin 5 is used for positive feedback as in Figure 15- For the fastest response time, tie both balance pins to VCC.

Certain sources will produce a cleaner comparator output waveform if a 100 pF to 1000 pF capacitor (C2) is connected directly across the input pins. When the signal source is applied through a resistive network, R1, it is usually advantageous to choose R2 of the same value, both for DC and for dynamic (AC) considerations. Carbon, tin-oxide, and metal-film resistors have all been used with good results in comparator input circuitry, but inductive wirewound resistors should be avoided.

When comparator circuits use input resistors (e.g., summing resistors), their value and placement are particularly important. In all cases the body of the resistor should be close

to the device or socket. In other words, there should be a very short lead length or printed-circuit foil run between comparator and resistor to radiate or pick up signals. The same applies to capacitors, pots, etc. For example, if  $R1 = 10\text{ k}\Omega$ , as little as 5 inches of lead between the resistors and the input pins can result in oscillations that are very hard to dampen. Twisting these input leads tightly is the best alternative to placing resistors close to the comparator.

Since feedback to almost any pin of a comparator can result in oscillation, the printed-circuit layout should be engineered thoughtfully. Preferably there should be a groundplane under the LM211 circuitry (e.g., one side of a double layer printed circuit board). Ground, positive supply or negative supply foil should extend between the output and the inputs to act as a guard. The foil connections for the inputs should be as small and compact as possible, and should be essentially surrounded by ground foil on all sides to guard against capacitive coupling from any fast high-level signals (such as the output). If Pins 5 and 6 are not used, they should be shorted together. If they are connected to a trim-pot, the trim-pot should be located no more than a few inches away from the LM211, and a 0.01  $\mu\text{F}$  capacitor should be installed across Pins 5 and 6. If this capacitor cannot be used, a shielding printed-circuit foil may be advisable between Pins 6 and 7. The power supply bypass capacitors should be located within a couple inches of the LM211.

A standard procedure is to add hysteresis to a comparator to prevent oscillation, and to avoid excessive noise on the output. In the circuit of Figure 16, the feedback resistor of 510  $\text{k}\Omega$  from the output to the positive input will cause about 3.0 mV of hysteresis. However, if  $R2$  is larger than 100  $\Omega$ , such as 50  $\text{k}\Omega$ , it would not be practical to simply increase the value of the positive feedback resistor proportionally above 510  $\text{k}\Omega$  to maintain the same amount of hysteresis.

When both inputs of the LM211 are connected to active signals, or if a high-impedance signal is driving the positive input of the LM211 so that positive feedback would be disruptive, the circuit of Figure 15 is ideal. The positive feedback is applied to Pin 5 (one of the offset adjustment pins). This will be sufficient to cause 1.0 mV to 2.0 mV hysteresis and sharp transitions with input triangle waves from a few Hz to hundreds of kHz. The positive-feedback signal across the 82 $\Omega$  resistor swings 240 mV below the positive supply. This signal is centered around the nominal voltage at Pin 5, so this feedback does not add to the offset voltage of the comparator. As much as 8.0 mV of offset voltage can be trimmed out, using the 5.0  $\text{k}\Omega$  pot and 3.0  $\text{k}\Omega$  resistor as shown.

**Figure 18. Relay Driver with Strobe Capability**

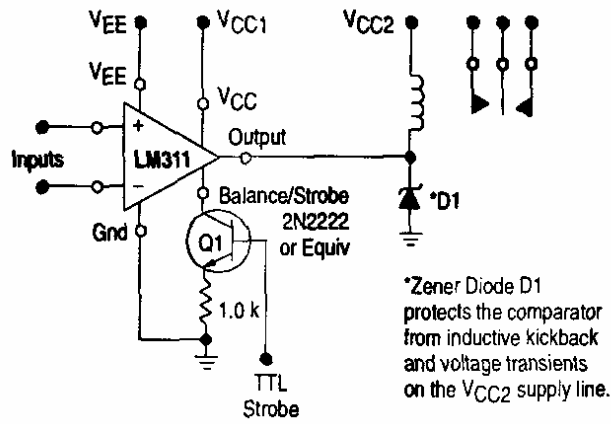

**Figure 17. Zero-Crossing Detector Driving CMOS Logic**

