

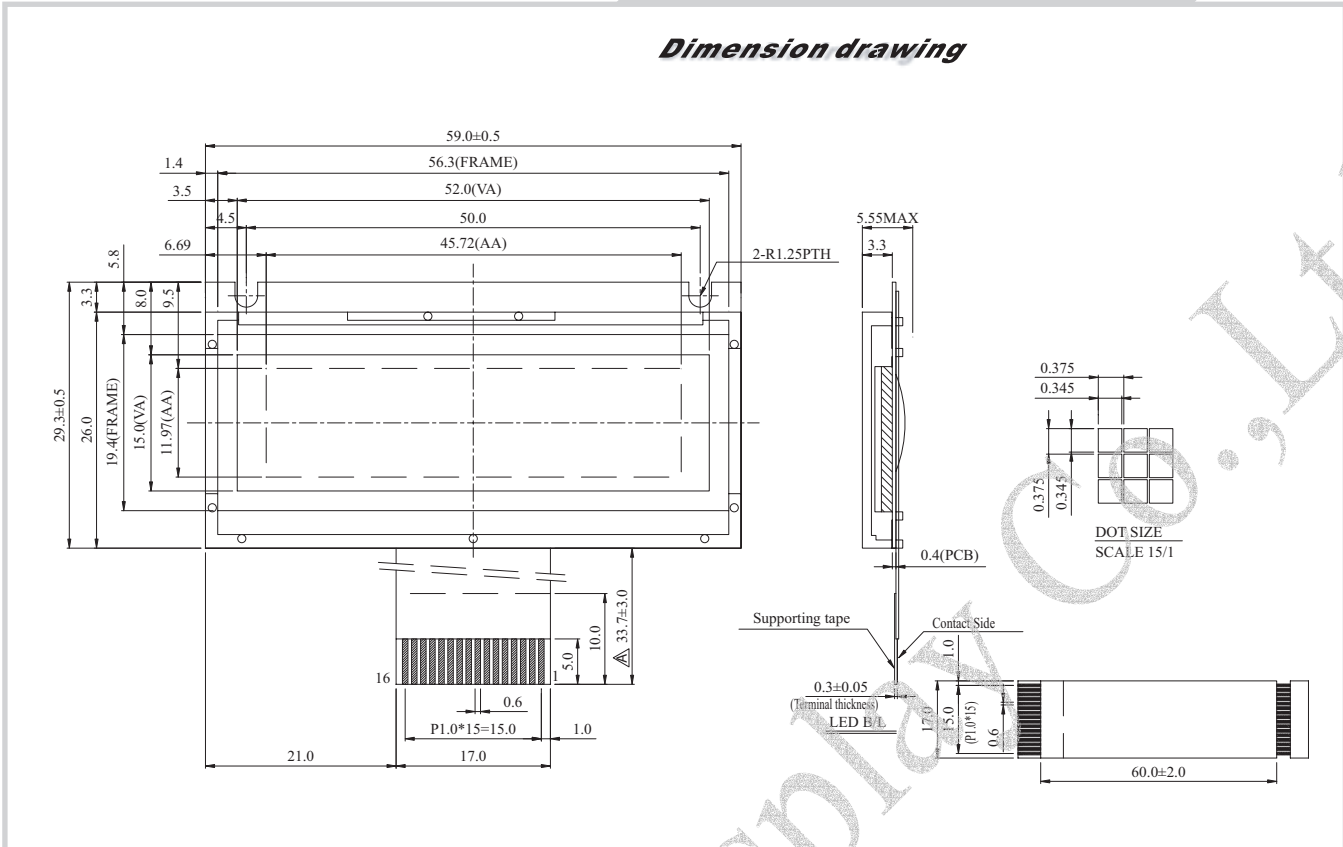

# WG12232I Graphic 122x32 dots

## Dimension drawing



### Feature

1. Built-in controller Epson-SED1520 (or Equivalent)
2. 1/32 duty cycle
3. FFC
4. Same size with WG12232D

### Mechanical Data

Item	Standard Value	Unit
Module Dimension	59.0x29.3x5.55	mm
Viewing Area	52.0x15.0	mm
Dot Size	0.345x0.345	mm
Dot Pitch	0.375x0.375	mm
Mounting hole	50.0x1.5	mm

Graphic type

Pin NO.	Symbol	Function
1	VLED	B/L Selected
2	VSS	Ground
3	VDD	Supply voltage for logic
4	VO	Operating voltage for LCD
5	AO	H: Data L: Instruction
6	E1	Enable chip1
7	E2	Enable chip2
8	DB0	Data bus line
9	DB1	Data bus line
10	DB2	Data bus line
11	DB3	Data bus line
12	DB4	Data bus line
13	DB5	Data bus line
14	DB6	Data bus line
15	DB7	Data bus line
16	R/W	H: read data L: write data

### Absolute Maximum Rating

Item	Symbol	Standard Value			Unit
		min.	typ.	max.	
Power Supply	VDD-VSS	2.75	5.0	5.25	V
Input Voltage	VI	0	---	VDD	V

Note: VSS=0 Volt, VDD=5.0 Volt.

### Electrical Characteristics

Item	Symbol	Condition	Standard Value			Unit
			min.	typ.	max.	
Input Voltage	VDD	---	---	5.0	---	V
Supply Current	IDD	VDD=5V	---	1.0	---	mA
Recommended LC Driving Voltage for Normal Temp. Version module	VDD-VO	-20°C	---	---	---	V
		25°C	---	4.85	---	
		70°C	---	---	---	
CCFL Starting Voltage	VFLS	25°C	---	---	---	Vrms
CCFL Driving Voltage	VFLD	25°C	---	---	---	Vrms
CCFL Driving Current	IFLD	VFG=450Vrms 30KHZ	---	---	---	mA
LED Forward Voltage	VF	25°C	---	4.2	---	V
LED Forward Current	IF	25°C	---	40.0	---	mA
EL Power Supply Current	IEF	Vel=110VAC:400Hz	---	---	5.0	mA